

BLSC Racing Rules for 2016

All races sponsored by the Beaver Lake Sailing Club (BLSC) shall be governed by the International Sailing Federation (ISAF) Racing Rules of Sailing 2013-2016 with the following exceptions:

- (1) Signal pennants will be limited to:
 - (a) Code AP (postponement, red-white alternating)
 - (b) Code S (shortened course, white with blue center)
 - (c) Code X (individual recall, white with blue cross)
 - (d) First Substitute (general recall, blue triangle with yellow center)
 - (e) Code N (race abandoned and return to starting area, blue-white checkerboard)
 - (f) Code N over B (race abandoned with no more racing today, Code N with solid blue flag)
 - (g) Code N over A (race abandoned with instructions ashore, Code N with solid red flag).
- (2) If boats compete in teams, then ISAF Team Racing Rules will not apply and provision (e) is added to Rule 41 which then reads

“41 OUTSIDE HELP

A boat shall not receive help from any outside source, except ...

(e) help, including electronic, from another boat on her team.”

- (3) The paragraph beginning “However, if requirement (b) is met” at the end of ISAF Rule 61.2 does not apply.

ISAF Racing Rules of Sailing 2013-2016 may be viewed at www.sailing.org/documents/racingrules .

BLSC Racing Instructions for 2016

The 2016 BLSC racing schedule consists of the following individual races and series of races:

Event	Description	Type	Course
Arkansas Cup	4 race days, 1 race/day, 1 throw-out if 4 races are sailed.	Series	Distance race
Founders' Day	1 race day with team racing	Single	Distance race
Raise-your-Sails (KOL)	2 race days, pursuit & short course	Series	Mixed
Spring Series	4 race days, 2 races/ day with 2 throw-outs if 8 races are sailed, 1 throw-out if 7 races are sailed.	Series	“round-the-buoys”
Fall Series	4 race days, 2 races/ day with 2 throw-outs if 8 races are sailed, 1 throw-out if 7 races are sailed.	Series	“round-the-buoys”

All “round-the-buoys” racing will be done on one of the following four types of courses, with roundings to port if a red placard is displayed and to starboard if a green placard is displayed:

- (1) Windward-leeward, with course designation "W". Rounding to port (red) is illustrated.
Note. If the leeward mark corresponds to both the start and finish lines, then a boat finishing will cross the finish line from the direction of the weather mark. If such a course is to be sailed twice around, then the start/finish line is a gate for the first circuit.
- (2) Triangle, with course designation "T". Rounding to port (red) is illustrated.
- (3) Dog-leg, with course designation "D". Rounding to port (red) is illustrated with a starboard rounding at the pin.
- (4) Gold Cup, with course designation "G". Rounding to starboard (green) is illustrated.

Note. Course designations may be used in combination. For example, "W 2 red" indicates that a windward-leeward course is to be sailed twice around, leaving all marks to port. "G red" is equivalent to "T red W red". "D T green" indicates that a dogleg should be followed by a triangle with marks left to starboard. Please check the placards displayed on the RC boat before the start of each race.

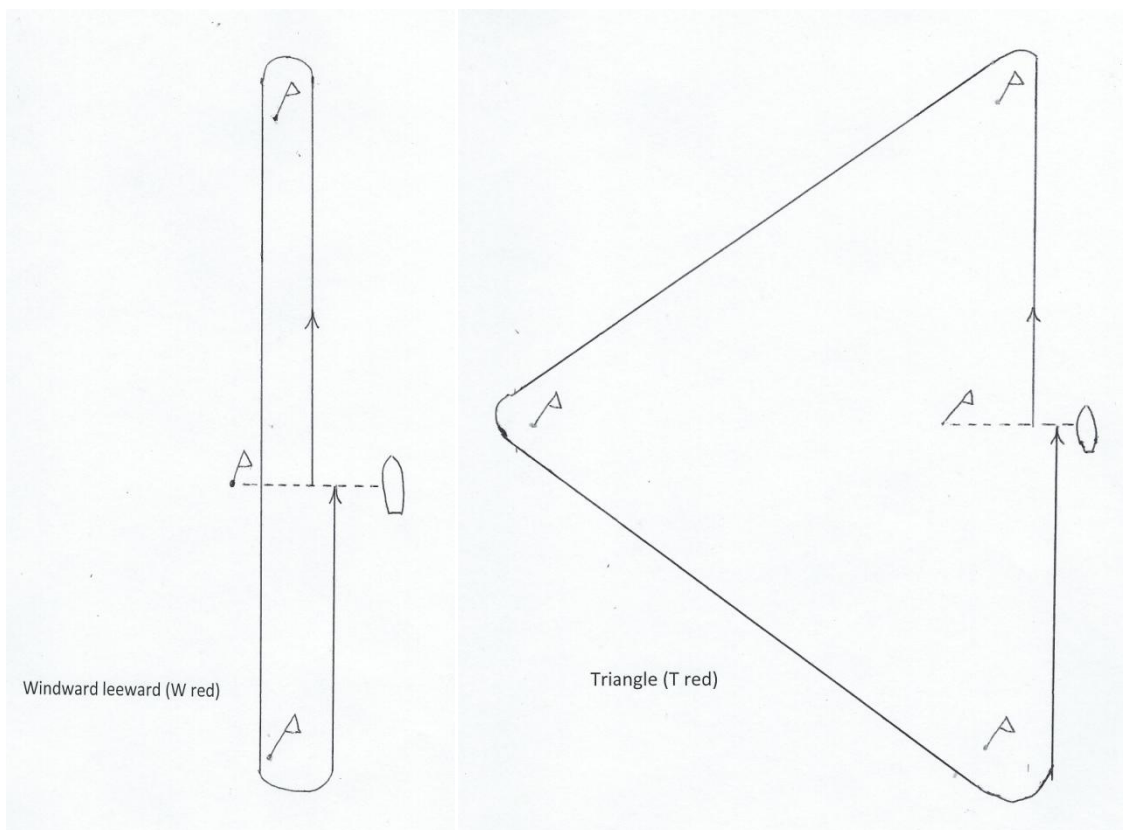

In General

Skippers' meeting. A skippers meeting will be held at the Club Pavilion at 11:00 AM each race day. For the Spring and Fall Series, the courses will be posted on the RC boat, and courses may change between races on the same day. Be sure to check the white board at the Pavilion for any additional instructions. The Preparatory signal (white flag) for the first start will occur at 12:05 PM unless otherwise indicated on the Pavilion whiteboard or the AP pennant is flown on the RC boat.

Fleets. A boat must declare before the first race of a series-of-races event or before a single-race event her intention to be in either one of two fleets:

Cruising Fleet. No boat may fly a spinnaker during that particular racing event.

Performance Fleet. A boat may optionally fly a spinnaker or not, consistent with the fastest way to complete the course.

A boat may switch between fleets from event to event but not within a particular event.

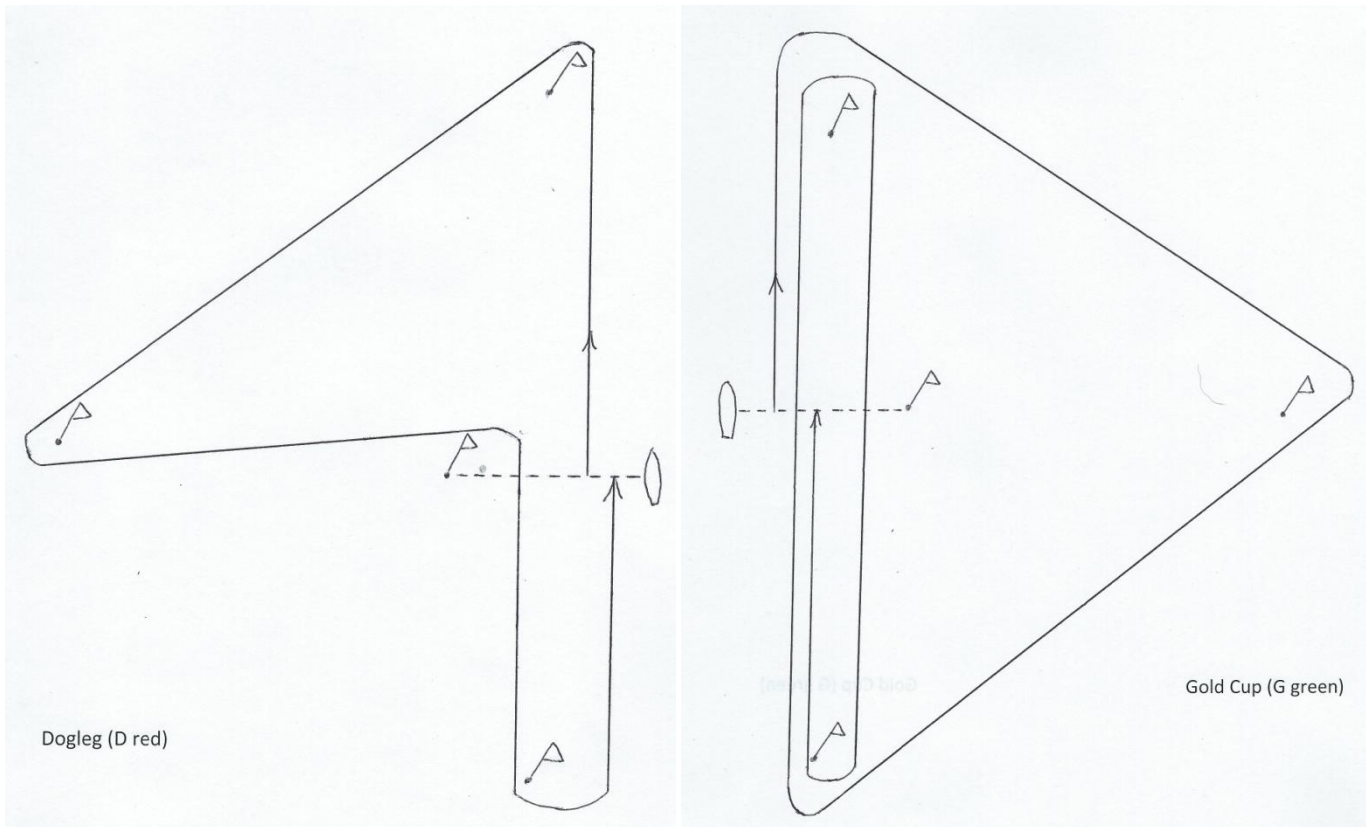

Starts and finishes. The starting sequence of each race will always proceed as follows;

A multiple sound signal will occur to warn all boats, followed approximately one minute later by

White flag up (sound signal)	Time = 0 minutes	
White flag down	Time = 4 minutes	
Blue flag up (sound signal)	Time = 5 minutes	Start of Cruising Fleet
Blue flag down	Time = 9 minutes	
Red flag up (sound signal)	Time = 10 minutes	Start of the Performance Fleet.

The start and finish line will always be between a buoy, the "pin", and the mast on the RC boat.

Recalls. Code X and First Substitute flags will be in use. The Race Committee will attempt to hail individual boats who are over early.

Shortened course.

“Around –the-buoys”: A shortened course signal will be made as the leading boat rounds a mark. Proceed to finish at the next mark.

Distance Race. A shortened course signal, if any, will be made on the hour, every hour, and every half hour. Proceed directly to the RC boat on station at the finish line.

Identification. All boats intending to race must identify themselves to the Race Committee either by registering prior to the Skipper’s meeting at the Pavilion, or barring that, by hailing the name of their boat to the RC prior to the white flag (10 minute signal) of the first race of the day.

Waiver of Liability. A “2016 Boat Owner’s Insurance and Liability Statement” must be on file with the Vice Commodore in order to race.

Handicaps. With the exception of the King-of-the-Lake (KOL) pursuit race and possibly the Founders’ Day Regatta, corrected times will be based on PHRF-based *time correction factors* (TCF), adjusted to compensate for three wind ranges (light air, 0-6 mph; medium air, 6 -18 mph; heavy air, > 18 mph). For the KOL race, time-on-distance corrections will be made using PHRFs corresponding to the medium air wind range. Appeals concerning PHRFs should be referred to the BLSC Handicap Committee (Mike Mayer, Ted Willis, Tom Unger).

Scoring. Low point scoring will be used with $\frac{3}{4}$ point being awarded for first place. DNF, DSQ, DNS and OCS receive one point higher than the number of boats who start the race. Exceptions if any will be announced at the Skipper’s meeting.

Protests. The “720 Rule” is in effect. If a boat intends to file a protest it must be in writing, on an appropriate form, and filed with any member of the BLSC Protest Committee (Rob Stivers, Mike Mayer, Ted Willis) or the Vice Commodore within 60 minutes of the time at which the RC boat reaches its dock on the day of the alleged infraction. The protestee will be allowed at least 60 minutes to review the protest.

Severe Conditions. No race will be started in sustained wind over 25 mph or with lightning in the vicinity.

12/3/2016