

Beaver Lake Sailing Club
2019 Sailing Instructions



B



L



S



C

RACING

The 2019 BLSC Fleet Racing schedule consists of the following individual races and series of races. For dates, see the racing calendar at the Racing tab on the [BLSC website](#).

EVENT	DESCRIPTION	TYPE	COURSE
Spring Series	4 race days, 2 races/day with 2 throw-outs if 8 Series "round-the-buoys" races are sailed, 1 throw-out if 7 races are sailed	Seires	Buoy racing
Arkansas Cup	3 race days, 1 race/day, 1 throw-out if 3 races are sailed	Series	Distance/buoy races
Founders' Day	2 day regatta	sprint races	Buoy racing
Ruler Of The Lake	A medium distance race	One day	TBD
Fall Series	4 race days, 2 races/day with 2 throw-outs if 8 Series "round-the-buoys" races are sailed, 1 throw-out if 7 races are sailed	Series	Buoy racing

Distance Races

- **Round Larue**
- **Starkey Sprint**
- **Rocky Branch Run**
- **The Dam Race**

Rules and Course Descriptions on the [BLSC website](#)

2019 Courses

All “round-the-buoys” racing will be done on one of the following types of courses, with roundings to port if a red placard is displayed and to starboard if a green placard is displayed:

(1) Windward-leeward, with course designation “W”. Rounding to port (red) is illustrated.

(2) Triangle, with course designation “T”. Rounding to port (red) is illustrated.

Note: Course designations may be used in combination. For example, “W 2 red” indicates that a windward-leeward course is to be sailed twice around, leaving all marks to port. “T2 red”.

indicates a triangle course is to be sailed twice around. Please check the placards displayed on the RC boat before the start of each race.

(3) Gold Cup, with course designation “G”. Rounding to starboard (green) is illustrated.

At the Vice-Commodore’s discretion, a race course may include natural terrain features, e.g, Starkey Island.

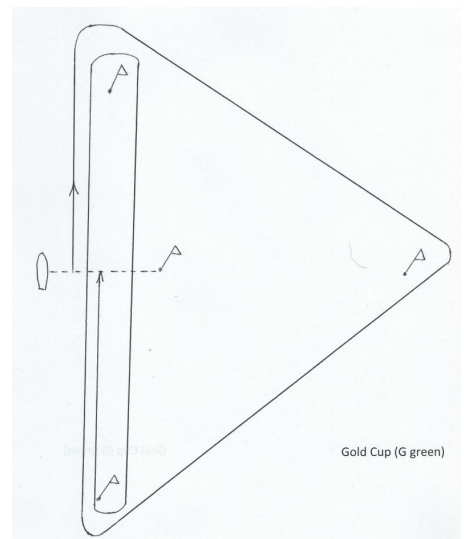
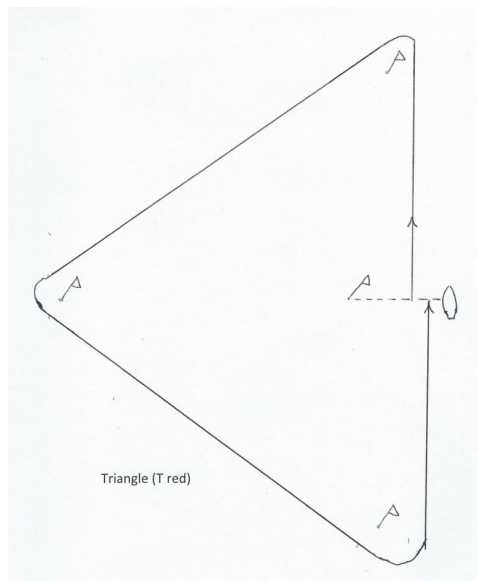
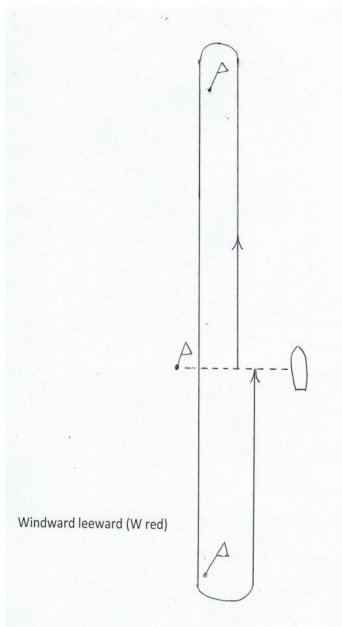

Check in/Skippers' Meeting. A Skippers' Meeting will be held at the Club Pavilion at 11:00 AM each race day. For the Spring and Fall Series, the courses will be posted on the RC boat, and courses may change between races on the same day. Be sure to check the white board at the Pavilion for any additional instructions. Skippers must attend this meeting for their first race of the year in order to register with their boat's required information and insurance documentation. This meeting also provides opportunities for in-depth briefings, questions, and discussion. Course designation and other information will be also displayed on the R/C boat in the form of placards and flags.

Class Flag for the first start will occur at or about 12:05 PM unless otherwise indicated on the Pavilion whiteboard or the AP pennant is flown on the RC boat.

Fleets. A boat may switch between fleets from event to event but not within a particular event. A boat must declare before the first race of a series-of-races event or before a single-race event her intention to be in either one of two fleets:

Cruising Fleet. No boat may fly a spinnaker during that particular racing event.

Performance Fleet. A boat may optionally fly a spinnaker or not, consistent with the fastest way to complete the course.

Two (2) 'Rule 26' Start Sequences Per Race

Races will be started using the following signals, per RRS Rule 26. Each race will have two separate five-minute start sequences—for the Cruising and Performance Fleets, respectively.

Each five-minute sequence is preceded by an alert consisting of a repetitive series of sound signals. All sound signals are short blasts except for the single LONG blast at one minute to start. *NOTE: Visual signals (flags UP-UP-DOWN-DOWN) are controlling— absence of a sound signal shall be disregarded.*

<i>Minutes before starting signal</i>	<i>Visual signal</i>	<i>Sound signal</i>	<i>Means</i>
5	Class flag- UP	One	Warning signal
4	P, I, Z, Z with I, U, or black flag- UP	One	Preparatory signal
1	Preparatory flag DOWN	ONE LONG	One minute to start
0	Class flag DOWN	One	Starting signal

Recalls. Code X and First Substitute flags will be in use. When individual recalls are signaled, the race committee may (at its discretion) attempt to hail the sail numbers of the recalled boats with display of Flag X and one sound. Failure of the RC to hail or failure of a boat to hear the hail of its sail number shall not relieve the boat of its obligation to start correctly nor grounds for redress. This changes RRS 29.1 and 62.1(a)

Shortened Course - Local exception to RRS Rule 32.3: If the Race Committee signals a shortened course, by displaying Code Flag S with two sounds, the next leg of the course is the new last leg and ends at the Finish Line at the RC Boat from the direction of the mark where signaled. The shortened course shall be signaled as the first boat rounds the mark or passes through the gate beginning the new last leg of the race. Display of Code Flag S, with 2 sounds, shall be continued as all subsequent boats round the mark or pass through the gate. **If a timely finish is in doubt, all boats are advised to monitor VHF Channel 68 for confirmation of a shortened course.**

Check in/Identification. All boats intending to race must identify themselves to the Race Committee either by registering prior to the Skipper's meeting at the Pavilion, or barring that, by hailing the name of their boat to the RC prior to the first sound signal/class flag of the first race of the day. Note that all skipper's must attend the skipper's meeting prior to their first race of the year in order to provide insurance and other required information.

Waiver of Liability. A current Boat Owner's Insurance and Liability Statement must be on file with the Vice-Commodore in order to race.

Handicaps. With the exception of the Founders' Day Regatta, corrected times will be based on PHRF-based *time correction factors* (TCF), adjusted to compensate for three wind ranges (**light air, 0-8 knots; medium air, 8-12 knots; heavy air, > 12 knots**). For the Ruler of The Lake race, time-on-time corrections will be made using PHRFs corresponding to the medium air wind range. Appeals concerning PHRFs should be referred to the BLSC Handicap Committee (Bill Corley, Johnny Walker, Malcolm Williamson).

Series Scoring. Low point scoring will be used with one point being awarded for first place, two points for second place, etc. DNF, DSQ, DNS and OCS receive one point higher than the number of boats who start the race. Exceptions if any will be announced at the Skipper's meeting.

Protests. The "720 Rule" is in effect. If a boat intends to file a protest it must be in writing, on an appropriate form, and filed with any member of the BLSC Protest Committee (Bill Corley, Johnny Walker, and Ted Willis) or the Vice Commodore, Bill Corley, within 30 minutes of the time at which the RC boat reaches its dock (indicated by one horn blast) on the day of the alleged infraction. The protestee will be allowed at least 60 minutes to review the protest.

Severe Conditions. No race will be started in sustained wind over 25 knots, lightning in the vicinity, air temperature below 45 or windchill value below 32 degrees Fahrenheit.

Rules. All races sponsored by the Beaver Lake Sailing Club (BLSC) shall be governed by the Racing Rules of Sailing 2017-2020 with the following exceptions:

- (1) Signal pennants will be limited to:
 - (a) Code AP (postponement, red-white alternating)
 - (b) Code S (shortened course, white with blue center)
 - (c) Code X (individual recall, white with blue cross)
 - (d) First Substitute (general recall, blue triangle with yellow center)
 - (e) Code N (race abandoned and return to starting area, blue-white checkerboard)
 - (f) Code N over A (race abandoned with no more racing today, Code N with blue and white swallow flag)
 - (g) Code N over H (race abandoned with instructions ashore, Code N with red/white flag).

Questions? vicecommodore@beaverlakesailclub.com

