

2020

Beaver Lake Sailing Club 2020 Sailing Instructions

V 2.6 — Effective September 6, 2020



B



L



S



C

RACING

The 2020 BLSC Fleet Racing schedule consists of the following events. Additional racing information at the [BLSC website](#).

SUMMER/FALL 2020 BLSC Racing Events - 081320		
Official Events		
Date	Event	Remarks
Saturday, May 23, 2020	Arkansas Cup #1	Pursuit Race - Start time assigned
Monday, May 25, 2020	Y-Flyer Racing	Warm up/Crew familiarization
Saturday, June 06, 2020	Molder Hollow Cup #1	One Design Racing: Y-Flyer Fleet - 1 pm start
Saturday, June 13, 2020	Founder's Day Regatta Day 1	11 am Skippers' Meeting Required/1 pm start
Sunday, June 14, 2020	Founder's Day Regatta Day 2	11 am Skippers' Meeting Required/1 pm start
Saturday, June 20, 2020	Molder Hollow Cup #2	One Design Racing: Y-Flyer Fleet - 1 pm start
Saturday, July 04, 2020	Arkansas Cup #2	Pursuit Race - Start time assigned
Saturday, July 11, 2020	Molder Hollow Cup #3	One Design Racing: Y-Flyer Fleet - 1 pm start
Saturday, July 25, 2020	Molder Hollow Cup #4	One Design Racing: Y-Flyer Fleet - 1 pm start
Saturday, August 22	Y-Flyer Fall Series - #1	One Design Racing: Y-Flyer Fleet - 1 pm start
Saturday, September 05, 2020	Arkansas Cup #3	Pursuit Race - Start time assigned
Monday, September 07, 2020	Y-Flyer Fall Series - #2	One Design Racing: Y-Flyer Fleet - 1 pm start
Saturday, September 12, 2020	Ruler Of The Lake	Pursuit Race - Start time assigned
Saturday, September 19, 2020	ROL or Ark Cup Make Up	TBD
Saturday September 19	Y-Flyer Fall Series - #3	One Design Racing: Y-Flyer Fleet - 1 pm start
Sunday, September 27, 2020	Keelboat Fall Series 1 & 2	1 pm start
Saturday, October 03, 2020	Y-Flyer Fall Series - #4	One Design Racing: Y-Flyer Fleet - 1 pm start
Sunday, October 11, 2020	Keelboat Fall Series 3 & 4	1 pm start
Saturday, October 17, 2020	Y-Flyer Fall Series - #5	One Design Racing: Y-Flyer Fleet - 1 pm start
Sunday, October 25, 2020	Keelboat Fall Series 5 & 6	1 pm start
Sunday, November 08, 2020	Keelboat Fall Series 7 & 8	1 pm start
Sunday, November 15, 2020	Keelboat Fall Series Makeup	TBD

Distance Races

- **Round Larue Race**
- **Starkey Sprint**

- **Rocky Branch Run**
- **The Dam Race**

Rules and Course Descriptions are on the [BLSC website](#) and in the notices case at the Club Pavilion.

Courses

All “round-the-buoys” racing will be on one of the following types of courses, with roundings to port if a red placard is displayed on the RC boat; to starboard if a green placard is displayed.

(1) Windward-leeward, with course designation “W”. Rounding to port (red) is illustrated.

(2) Triangle, with course designation “T”. Rounding to port (red) is illustrated.

Note: Course designations may be used in combination. For example, “W 2 red” indicates that a windward-leeward course is to be sailed twice around, leaving all marks to port. “T2 red” indicates a triangle course is to be sailed twice around. Please check the placards displayed on the RC boat before the start of each race.

(3) Gold Cup, with course designation “G”. Rounding to starboard (green) is illustrated.

At the Vice-Commodore’s discretion, a race course may include natural terrain features, e.g, Starkey Island, Slate Gap Island, etc.

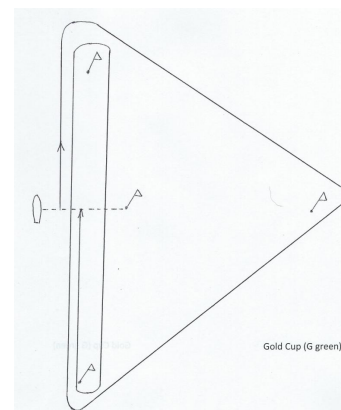
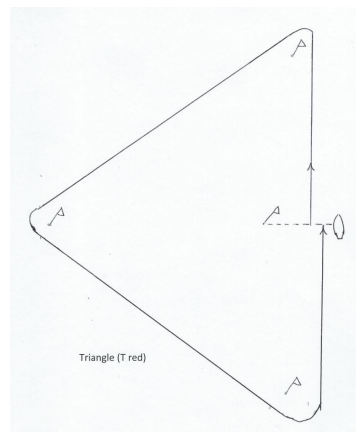
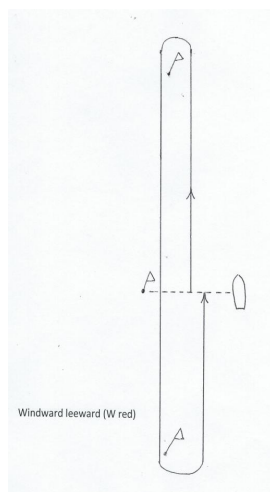

Preferred BLSC Buoy Race Course

Unless advised otherwise by the Race Committee, BLSC 2020 default buoy racing instructions are as follows:

1. Cruising fleet (**blue class flag**) starts first—normally at or about 1 pm
2. Performance fleet stays clear of start line area during the cruising fleet's five-minute start sequence
3. Cruising fleet completes Triangle course in one lap, port rounding, with upwind finish. Placarded on RC boat as T 1 (red)
4. Performance fleet (**red class flag**) completes Windward-Leeward course in 1 or 2 laps (placarded on RC boat), port rounding, with upwind finish. Placarded as W 2 (red)
5. W-L rhumb line distance: .5 to 1.2 NM depending on winds
6. Start line open

Check-in/Skippers Meeting

PANDEMIC NOTE: due to Covid 19 precautions, Skippers Meetings are on hold until further notice. To check in, each boat shall approach the Race Committee boat on starboard tack and hail the RC with its sail number, spinnaker intention, and boat name prior to the preparatory flag for their fleet. Note that skippers must still register ashore before participating of any series or event in order to provide their boat's required information and sign crew waiver forms. For all 'round-the buoy' races, including the Spring and Fall Series, course designation and other information will also be displayed on the R/C boat in the form of placards and flags. Courses may change between races on the same day. Be sure to check the white board at the Pavilion for any additional instructions. There will normally be a Race Committee member on hand at the pavilion to assist with paperwork and questions.

For all races at BLSC, the first start will occur at or about **1:00 PM** unless otherwise indicated on the Pavilion whiteboard or the AP pennant is flown on the RC boat.

PHRF Fleet Divisions

Prior to the first race of 2020 racing, the Race Committee will use algorithmic calculations based on each boat's published technical specifications to designate and assign club member-owned boats as either cruising fleet (**BLUE** class flag) or performance fleet (**RED** class flag) competitors. (See attached fleet determination chart on page 9)

(cont'd)

Boats from both fleets may elect to fly a spinnaker in addition to headsails and mainsails. At the initial registration for each series or event, the owner will indicate their chosen sail plan for that event or race series. For post-race scoring, each boat's elapsed time will be corrected using a PHRF handicap calculated for its chosen sail plan for that event or race series. Sign-in sheet choices are (check each option that applies):

- No spinnaker
- (AS) Asymmetrical Spinnaker
- (SS) Symmetrical Spinnakar

- A boat may choose a different sail plan (and corresponding PHRF handicap) between race events/series, but not within the same event or series.
- A designated cruising fleet boat may at the owner/skipper's discretion, elect to compete in the performance fleet within a given event or race series, and must so commit for that event or race series.

One Design Racing

One Design racing currently includes the Y-Flyer fleet, which will normally schedule races to avoid conflict with PHRF Fleet racing events.

Two (2) 'Rule 26' Start Sequences Per Race

Keelboat races will be started using the following signals, per RRS Rule 26. Each race will have two separate five-minute start sequences—for the Cruising and Performance Fleets, respectively. Each five-minute sequence is preceded by an alert consisting of a repetitive series of sound signals. All sound signals are short blasts except for the single LONG blast at one minute to start. *NOTE: Visual signals (flags UP-UP-DOWN-DOWN)) are controlling— absence of a sound signal shall be disregarded.*

<i>Minutes before starting signal</i>	<i>Visual signal</i>	<i>Sound signal</i>	<i>Means</i>
5	Class flag- UP	One	Warning signal
4	Preparatory flag "P" UP	One	Preparatory signal
1	Preparatory flag DOWN	ONE LONG	One minute to start
0	Class flag DOWN	One	Starting signal

The Y-Flyer Fleet will use the standard 3-minute dinghy racing start sequence.

Recalls. Code X and First Substitute flags will be in use. When individual recalls are signaled, the race committee may (at its discretion) attempt to hail the sail numbers of the recalled boats with display of Flag X and one sound. Failure of the RC to hail or failure of a boat to hear the hail of its sail number shall not relieve the boat of its obligation to start correctly nor grounds for redress. This changes RRS 29.1 and 62.1(a)

Check in/Identification. All boats intending to race must identify themselves to the Race Committee either by registering prior to the Skipper's meeting at the Pavilion, or by approaching the R/C boat on starboard tack and hailing their sail number, name of their boat, and planned spinnaker usage to the RC prior to the first sound signal/class flag of the first race of the day. Note that all skipper's must complete required paperwork at the BLSC pavilion prior to participation in each single race day event or before the first race in a series.

Shortened Course - Local exception to RRS Rule 32.3: If the Race Committee signals a shortened course, by displaying Code Flag S with two sounds, the next leg of the course is the new last leg and ends at the Finish Line at the RC Boat from the direction of the mark where signaled. The shortened course shall be signaled as the first boat rounds the mark or passes through the gate beginning the new last leg of the race. Display of Code Flag S, with 2 sounds, shall be continued as all subsequent boats round the mark or pass through the gate. **If a timely finish is in doubt, all boats are advised to monitor VHF Channel 68 for confirmation of a shortened course.**

Time Limits

Pursuit Races - If no boat rounds the furthest turning mark within 2.0 hours, the race will be abandoned. If no boat is able to sail the course and finish in 4.0 hours, the race will be abandoned. All competing boats that are unable to finish within 1.0 hour after the first boat to sail the course and finish within 4.0 hours will be scored as TLE and scored points equal to one point plus the number of boats completing the race within the 1st Place finish time plus 1.0 hour time limit.

PHRF Fleets Buoy Races - If no boat rounds the first turning mark within 1.0 hours, the race will be abandoned. If no boat is able to sail the course and finish in 2.0 hours, the race will be abandoned. All competing boats that are unable to finish within 60 minutes after the finishing time of the first boat in their class to sail the course and finish within 2.0 hours will be scored as TLE and scored points equal to one plus the number of boats in their class completing the race within the 1st Place finish time plus 1.0 hour time limit.

One Design Fleets Buoy Races - The time limits for each race will be 1.0 hours, and .5 hours for the first boat to round the first turning mark. Boats that do not complete the course within 1.0 hours may be finished in place if their finishing positions can be correctly determined. If a boat agrees to be finished in place her, finish place will be adjusted so as not to finish in front of

boats that finish within the time limit. Boats that cannot be placed will be assigned a Did Not Finish (DNF) designation and scored accordingly.

Waiver of Liability. A current Boat Owner's Insurance and Liability Statement must be on file with the Race Committee in order to race.

Handicaps. Corrected times will be based on time-on-time, PHRF-based *time correction factors* (TCF), and adjusted to compensate for three wind ranges (**light air, 0-8 knots; medium air, 8-12 knots; heavy air, > 12 knots**). For pursuit races, handicap corrections will be calculated using time-on-distance time correction factors. Appeals concerning PHRFs should be referred to the BLSC Handicap Committee (Bill Corley, Johnny Walker, Abram Barker).

Series Scoring. Low point scoring will be used with one point being awarded for first place, two points for second place, etc. DNF, DSQ, DNS, OCS, and RET receive one point higher than the number of boats that came to the starting area. DNC boats receive one point more than the number of boats entered in the series. Time limits apply and TLE boats are scored accordingly.

Protests. If a boat intends to file a protest it must be communicated to any member of the BLSC Protest Committee (Bill Corley, Johnny Walker, and Ted Willis) or the Vice-Commodore (Bill Corley), within 30 minutes of the time at which the RC boat reaches its dock (indicated by one horn blast) on the day of the alleged infraction. Note that the protesting boat must immediately display a red protest flag and hail the offending boat in response to the incident.

Severe Conditions. No race will be started in sustained wind over 25 knots, lightning in the vicinity, or weather conditions outside acceptable limits per the chart below.

Instructions: With current Wind, Air and Water temperatures:

- 1) Determine Wind Chill Temperature (WCT).
- 2) Determine Air Go - No.
- 3) If pass on Air Go - No Go, then determine Weather Go - No Go.
- 4) If Pass on Weather Go - No Go, then determine Water Go - No Go.

1) Chart - Wind Chill Temperatures

WCT	Wind (kts)															
Air Temp (F)	0	2	4	6	8	10	12	14	16	18	20	22	24	26	28	30
72	72	72	72	72	72	72	72	72	72	72	72	72	72	72	72	72
70	70	70	70	70	70	70	70	70	70	70	70	69	69	69	69	69
68	68	68	68	68	68	68	68	68	67	67	67	67	67	66	66	66
66	66	66	66	66	66	66	65	65	65	65	64	64	64	64	64	63
64	64	64	64	64	64	63	63	62	62	62	62	61	61	61	61	61
62	62	62	62	62	61	61	60	60	60	59	59	59	59	58	58	58
60	60	60	60	59	59	58	58	57	57	57	56	56	56	56	55	55
58	58	58	58	57	56	56	55	55	54	54	54	53	53	53	53	52
56	56	56	55	54	54	53	53	52	52	51	51	51	50	50	50	50
54	54	54	53	52	51	51	50	50	49	49	48	48	48	47	47	47
52	52	52	51	50	49	48	47	47	47	46	46	45	45	45	44	44
50	50	50	48	47	46	46	45	44	44	43	43	43	42	42	42	41
48	48	48	46	45	44	43	42	42	41	41	40	40	40	39	39	39
46	46	46	44	42	41	41	40	39	39	38	38	37	37	37	36	36
44	44	44	41	40	39	38	37	37	36	36	35	35	34	34	34	33
42	42	42	39	38	36	36	35	34	33	33	32	32	32	31	31	30
40	40	39	37	35	34	33	32	32	31	30	30	29	29	28	28	28
38	38	37	34	33	32	31	30	29	28	28	27	27	26	26	25	25
36	36	35	32	30	29	28	27	26	26	25	24	24	23	23	23	22
34	34	33	30	28	27	26	25	24	23	22	22	21	21	20	20	19
32	32	30	27	26	24	23	22	21	20	20	19	19	18	18	17	17
30	30	28	25	23	22	20	19	19	18	17	17	16	15	15	14	14

(NWS Wind Chill Equation)

4) Water Go - No Go

Is the Wind Chill Temperature above the minimum for the corresponding Water Temperature?

Water Temperature	Minimum Wind Chill Temp.
<40	72
40	72
42	70
44	66
46	62
48	58
50	54
52	50
54	46
56	42
58	38
60	36
62	32
>62	32

2) Air Go – No Go

Is stuff falling out of the sky (i.e. precipitation)?

If **yes**, Go if Wind Chill Temperature >50 degrees

If **no**, Go if Wind Chill Temperature >32 degrees

3) Weather Go - No Go

Are any of the weather conditions below occurring?

If **yes**, No Go

If **no**, Go

Lightning (<10mi); Wait 20 min after last strike

Wind Advisory

Tornado Warning

Ice Storm Warning

High Wind Warning

Dense Fog Advisory

Winter Weather Warning







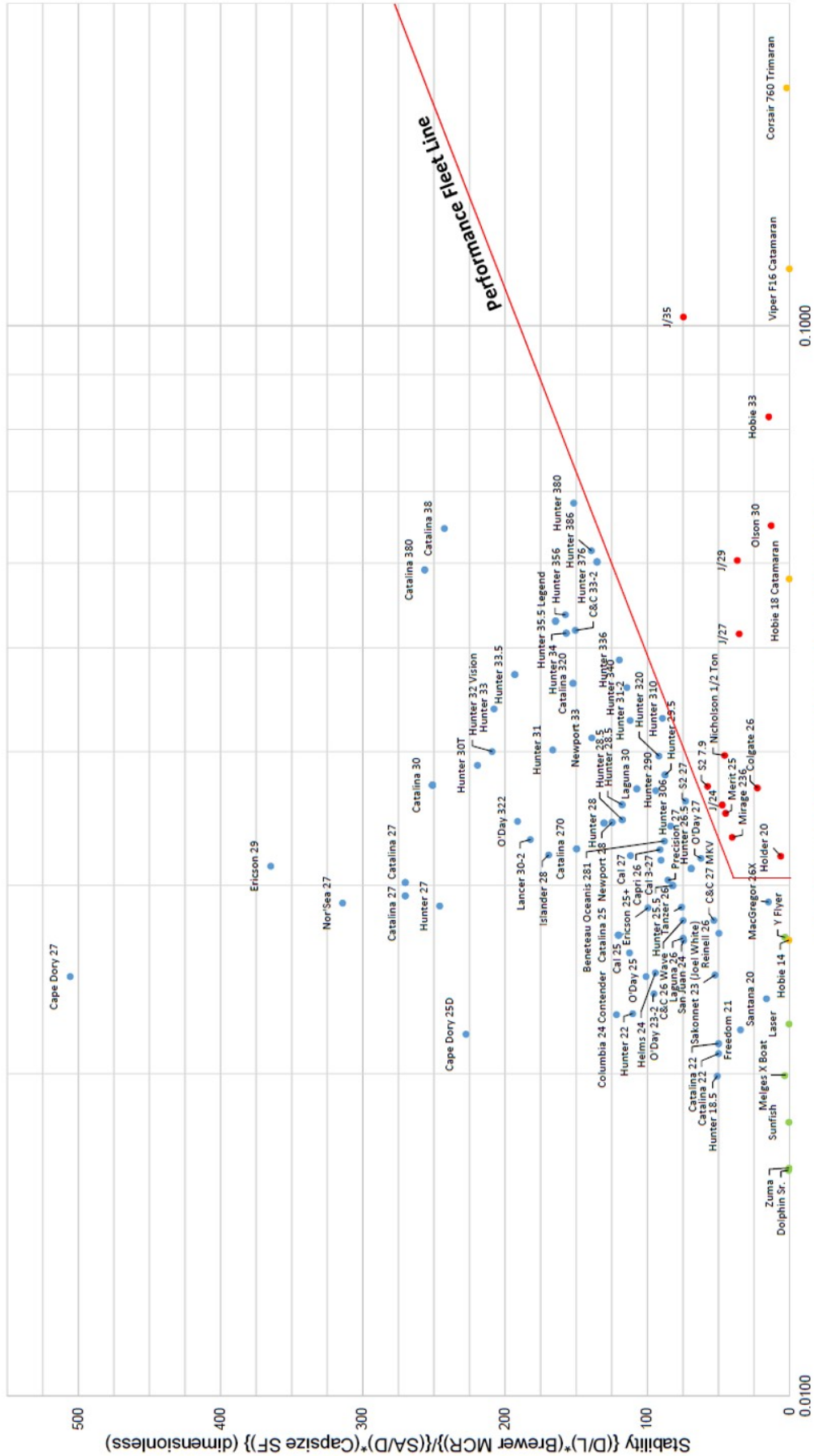

Severe Thunderstorm Warning

Special Weather Statement - Hail, Sleet, Winds

Fleet Determination Chart



Signal pennants will be limited to:

- Code AP (postponement, red-white alternating) 
- Code S (shortened course, white with blue center) 
- Code X (individual recall, white with blue cross) 
- First Substitute (general recall, blue triangle with yellow center) 
- Code N (race abandoned and return to starting area, blue-white checkerboard) 
- Cruising fleet class flag (solid blue) 
- Performance fleet class flag (solid red) 
- Y-Flyer fleet class flag (solid white) 
- Code P preparatory flag (white square inside blue outline) 

Questions? vicecommodore@beaverlakesailclub.com
(479) 466-5879

